

SB6432

Programmable **RGB**-backlit
LCD Push-button Switch

TABLE OF CONTENTS

General Description	4
Innovative Product Features	4
Resolution.....	4
RGB Colors.....	4
Color Calibration.....	4
Self-Initialisation.....	4
Enhanced Command Set.....	5
Improved Durability.....	5
Mounting Methods.....	5
Low Power Consumption.....	5
Technical Overview	6
SB6432	7
Dimensions.....	7
Keypad.....	7
Layout.....	8
Drill Masks.....	8
Mounting Methods.....	9
Liquid Crystal Display.....	10
Environmental Specifications.....	11
Electrical Specifications.....	11
Interfacing SB6432	12
Contact Terminals.....	12
Block Diagram.....	12
Serial Protocols.....	13
The Advanced Technology™ Mode.....	13
Legacy Mode™.....	13
Advanced Technology™ Mode.....	13
Timing Diagram.....	14
Command Set.....	15
Synchronous Protocol.....	15
Command and Data Formats.....	15
Commands for mixed use with/without permanent clock.....	16
Additional Commands only available in keys with Enhanced Command Set.....	17
Command Examples.....	18
Bit / Pixel Mapping.....	20
Display Memory – Internal RAM Structure.....	20
Bit/Pixel Mapping Table for SB6432.....	21
Controlling SB Switch Arrays	22

Notices.....23
 Copyright Notice.....23
 Technical Notice.....23
 Flammability Ratings.....23
 Warranty Disclaimer.....23
Ordering Information.....24
Change History.....24

GENERAL DESCRIPTION



The SB6432 switch is a programmable LCD keyswitch with command-driven serial interfaces. The SB6432 integrates a graphical liquid crystal display with **RGB** backlighting in a keyswitch.

The SB6432 keys are controlled via a serial interface to the integrated *Advanced Technology*[™] electronics, which control the interface, display and backlighting. The SB6432 self-initialises without external setup commands. Data only needs to be transmitted when a change is made to the display or background colors.

Only six contact terminals are needed to provide power, clock and data lines as well as switch contacts. The contact pins of the internal switch are isolated from the internal electronics.

INNOVATIVE PRODUCT FEATURES

Resolution

SB6432 64x32 pixels

RGB Colors

SB6432 supports over 1 million **RGB** colors.

Color Calibration

No color sorting due to *Advanced Technology*[™] electronics. The **RGB** backlighting of all keyswitches is calibrated for maximum uniformity.

Self-Initialisation

All keys self-initialise. No external setup commands required.

Enhanced Command Set

- ✓ Write Display data with 8 data bits per transmitted data byte
- ✓ Turn Display OFF, while maintaining bitmap
- ✓ Turn Display ON; restoring last transferred bitmap
- ✓ Additional color command including more than 100 brightness settings
- ✓ Grouping of keys for simultaneous addressing and changing of color settings (flashing)

Improved Durability

Over 3 million cycles for keyswitch element

Mounting Methods

Socket pins and socket locks

Low Power Consumption

Less than 65mA maximum current is needed when bright white backlighting is selected. Typical value is less than 25mA with one of the **RGB** colors.

TECHNICAL OVERVIEW

Features	SB6432
Resolution	64 x 32
RGB backlight colors	over 10,000 RGB colors
Interfaces	Synchronous serial 8-bit interfaces (custom protocols available upon request)
External clock	No external clock required
Self-initialisation	Yes
Maximum speed	2 MBaud
Operating supply	4.9 V to 5.1 V
Keyswitch type	tactile, 2.0 mm travel with over travel protection
Keyswitch life time	> 3.0 million cycles
Contact resistance	< 200 Ohm
Operating temperature	0°C to 55°C
Storage temperature	-20°C to 65°C

SB6432

Dimensions

Dimensions (X x Y x Z) 24.5 x 23.5 x 26.0 mm + / - 0,2 mm
Screen size (X x Y) 20.0 x 16.5 mm + / - 0.1 mm

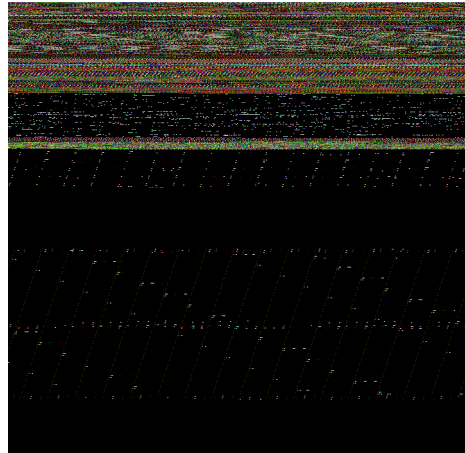
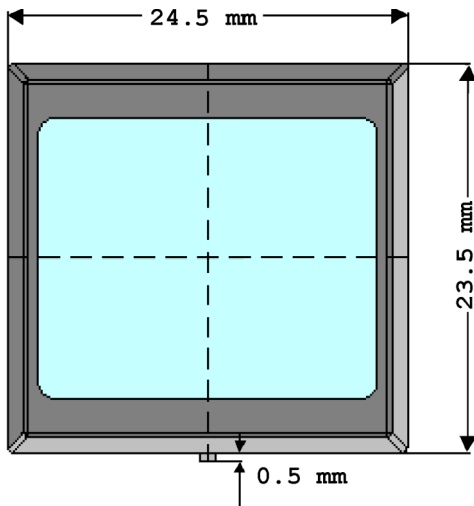

Keyswitch

Key stroke 2.0 mm +/- 0.1 mm; tactile
Operation force: 1.3 N +/- 0.2 N
Over travel protection: yes
Lifetime: 3 million cycles

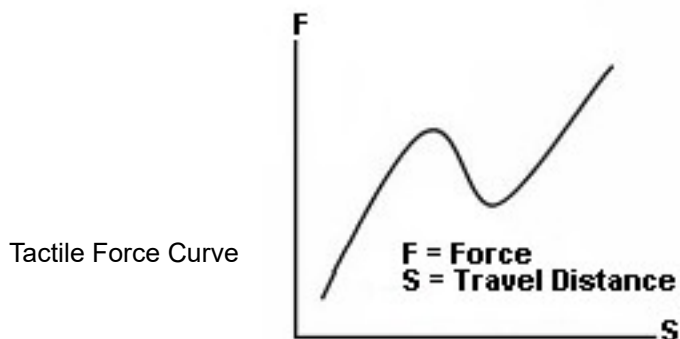

Layout

Direct PCB Mount
(top view)

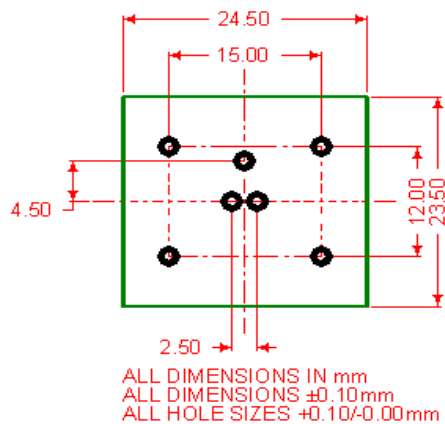

● $\varnothing 1.00$ PTH HOLE x $\varnothing 2.00$ PADS

Socket Mount
top view)

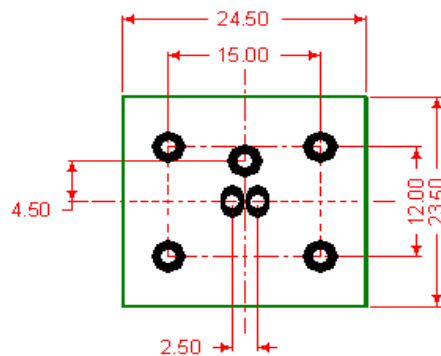

● $\varnothing 1.50$ PTH HOLE x $\varnothing 2.00 \times 3.20$ PADS

● $\varnothing 1.50$ PTH HOLE x $\varnothing 3.20$ PADS

Drill Masks

for direct soldering
(top view)

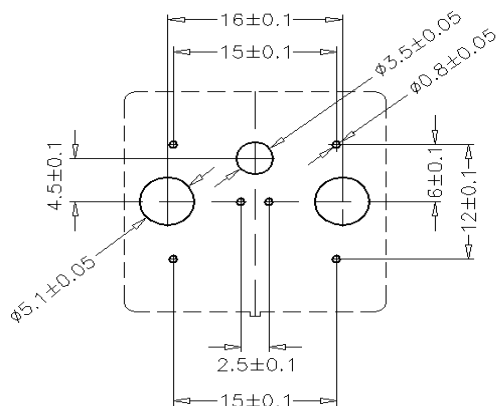

for use with socket pins
(top view)

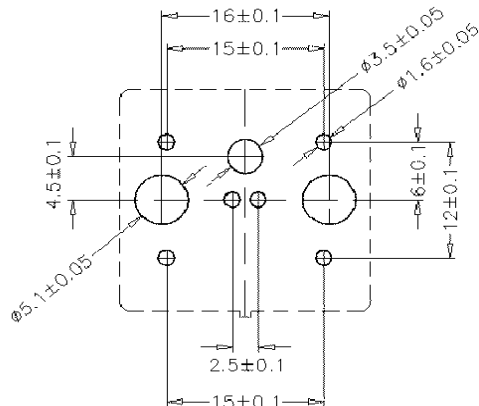

Recommended distance for array assembly is 1mm between each key.

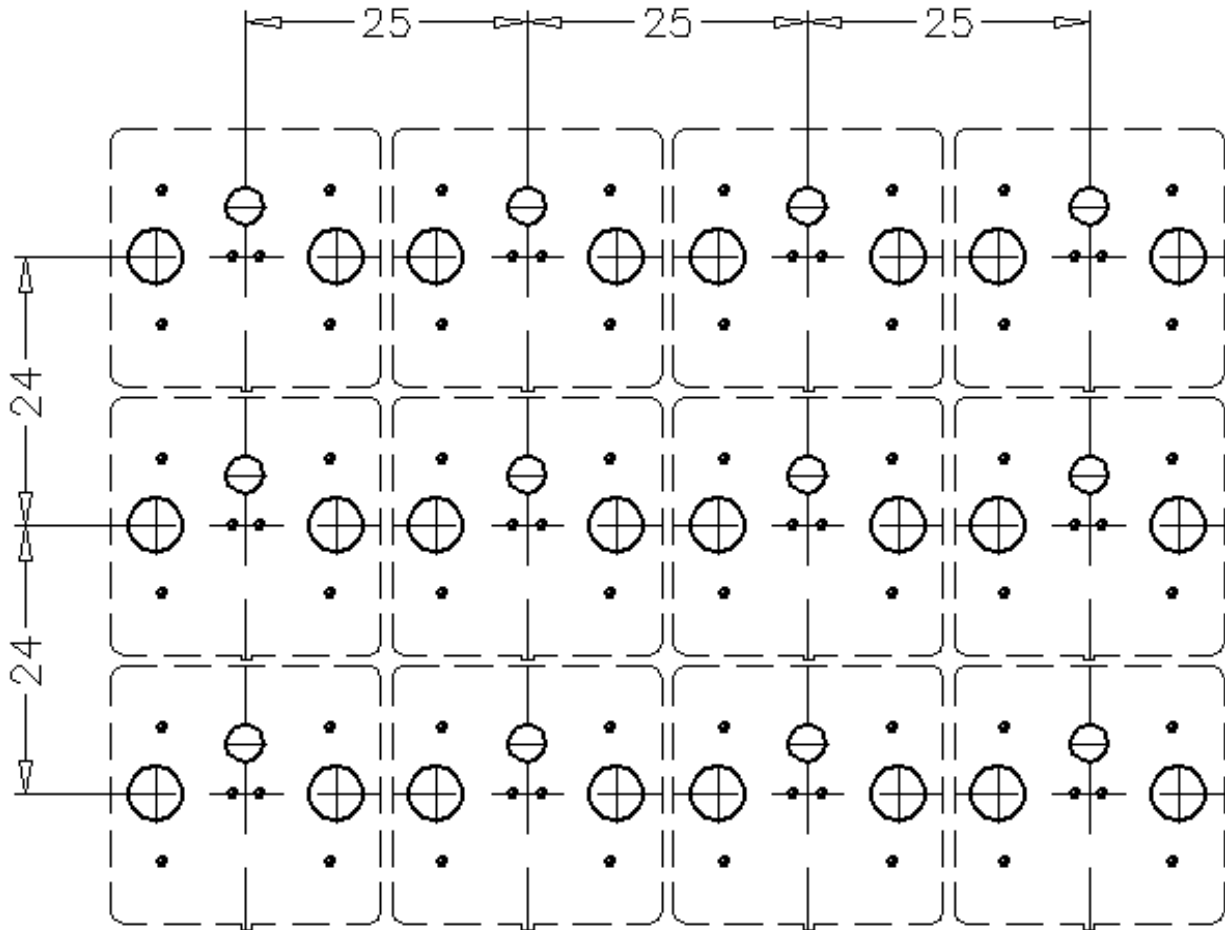

Mounting Methods

Socket mountable (see corresponding Drill Mask). Socket pins (**SP0000**) are used for field-exchangeable mounting.

Through-hole mountable on PCBs with 1.6mm and 2.0mm thickness.

Manual soldering: max. 350° C for max. 3.5 seconds per pin

Wave soldering: 260° C for 10 seconds

Liquid Crystal Display

Screen Size (X x Y) 17.26 mm x 12.14 mm
Pixel Size (X x Y) **SB6432** 0.25 mm x 0.36 mm

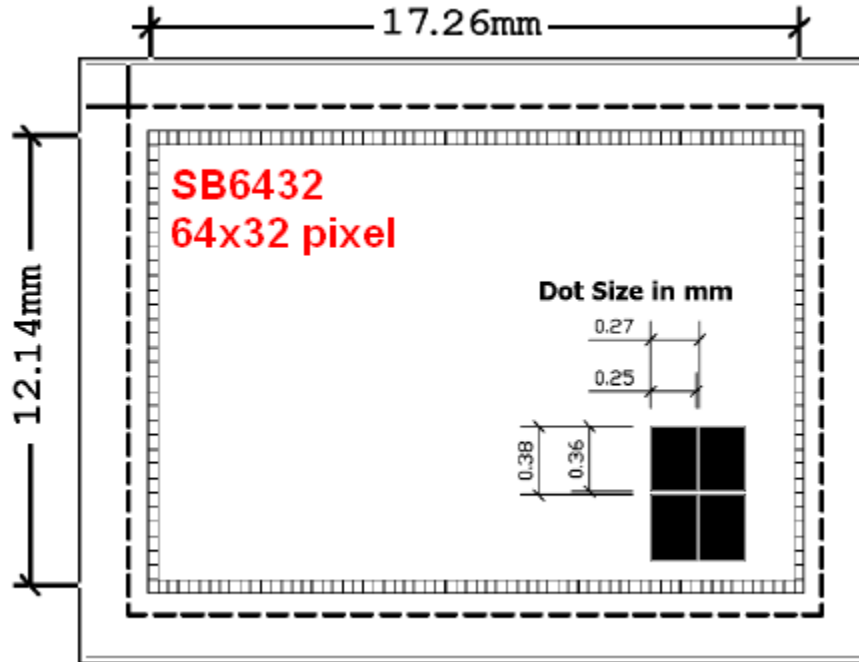

Environmental Specifications

Operating temperature 0°C to 55°C
Storage temperature -20°C to 65°C
Humidity up to 75% relative humidity at 65°C

Electrical Specifications

Operating voltage 4.9 V to 5.1 V
Current consumption max. 65 mA; typ. < 30 mA; min. 8 mA
Contact resistance < 200 Ohm
Insulating resistance > 100 MOhm

Symbol	Parameter	Min.	Typ.	Max.	Unit
$V_{DD}^{*1)}$	Operating voltage	4.9		5.1	V
$I_{DD}^{*2)}$	Supply current	8	<30	65	mA
V_{IN}	Input voltage on any pin			$V_{SS} - 0.3 - V_{DD} + 0.3$	V
I_{DIO}	Output data current sunk/source			+/- 5	mA
I_{CIO}	Output clock current sunk/source			+/- 5	mA
V_{IL}	Input low level voltage	$V_{SS} - 0.3$		$0.3 \times V_{DD}$	V
V_{IH}	Input high level voltage	$0.7 \times V_{DD}$		$V_{DD} + 0.3$	V
C_{CIO}	I/O clock pin capacitance		10		pF
$C_{DIO}^{*3)}$	I/O data pin capacitance			30	pF

*1) Voltage range to ensure proper display contrast restricted to 4.9V to 5.1V

*2) Special power saving models available on request

*3) The I/O data pin capacitance will be reduce in future products without notice.

INTERFACING SB6432

Contact Terminals

Pin	Symbol	Description	Comment
1	GND	negative (ground) power terminal	0.0 V
2	+ 5V	positive power terminal	+4.9 V – +5.1 V
3	CLOCK	clock line to synchronize data write and for internal use	60 kHz – 2 Mhz HIGH when inactive
4	DATA	command and data line to internal <i>Advanced Technology™</i> electronics	HIGH when inactive; see data format for details
5	SW1	switch contact	contact resistance < 200 Ohm
6	SW2	switch contact	contact resistance < 200 Ohm

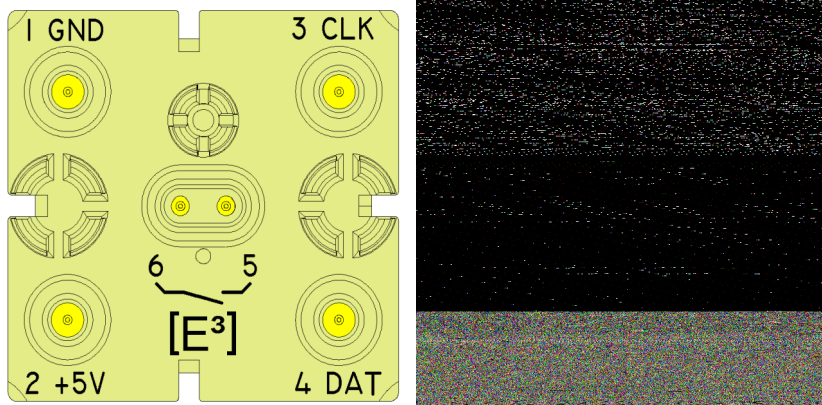

Pin View (terminal name and number are also marked on the keyswitch)

Block Diagram

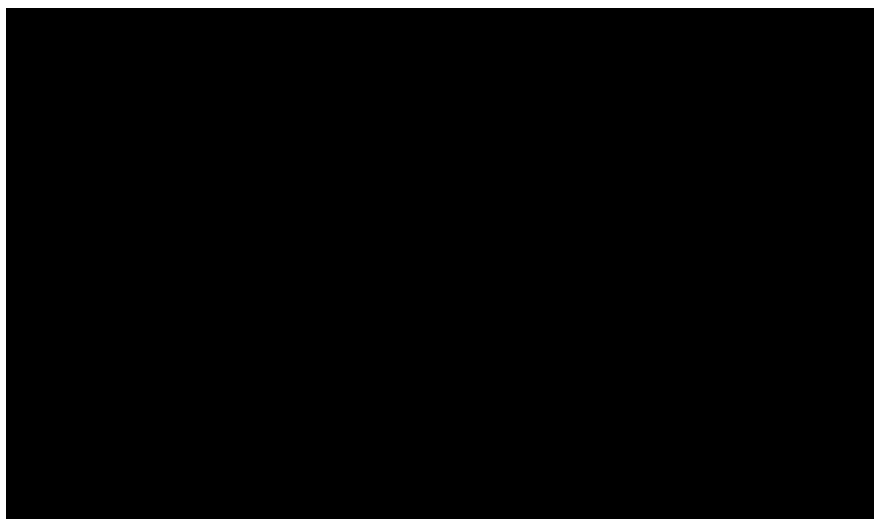

Serial Protocols

The SB6432 keyswitches are connected to the controlling central processing unit by a 2 wire serial connection.

The Advanced Technology™ Mode

Additional protocols are available upon request. Please contact your local [E³] distributor or [E³] directly at techsupport@e3-keys.com.

Feature	Advanced Technology™ Mode
Clock Frequency	up to 2 MHz
Permanent Clock	No
Data Word Size	8 bit
Internal Serial Number	Yes*

* To take advantage of these advanced functions your hardware must ensure that the SA keys are actively driving the serial data lines in *Advanced Technology™* mode.

Legacy Mode™

Legacy Mode™ is not supported in the SB switches.

Legacy Mode™ is only supported in the SA3216 and SA3624 switches as well as special versions of the SA3624 switch variant.

Advanced Technology™ Mode

This is the standard mode for controlling SB keyswitches and provides full access to all capabilities of the SB6432 keys. The details of this control protocol are documented in the subsequent paragraphs

The **Advanced Technology™** Mode uses a conventional synchronous protocol. A permanently applied clock is not necessary. Please make sure that inactive Clock and Data are set to “high” state.

The only difference to a true 8-bit synchronous data transmission is that the data may also be synchronized to a permanently applied clock. No parity checking/generation is required.

Since it is possible that the clock is applied permanently a StartBit is required to be able to detect the start of a transmission. To allow for a StartBit in a standard synchronous SPI the MSB of the DataByte is to be set to 0.

Timing Diagram

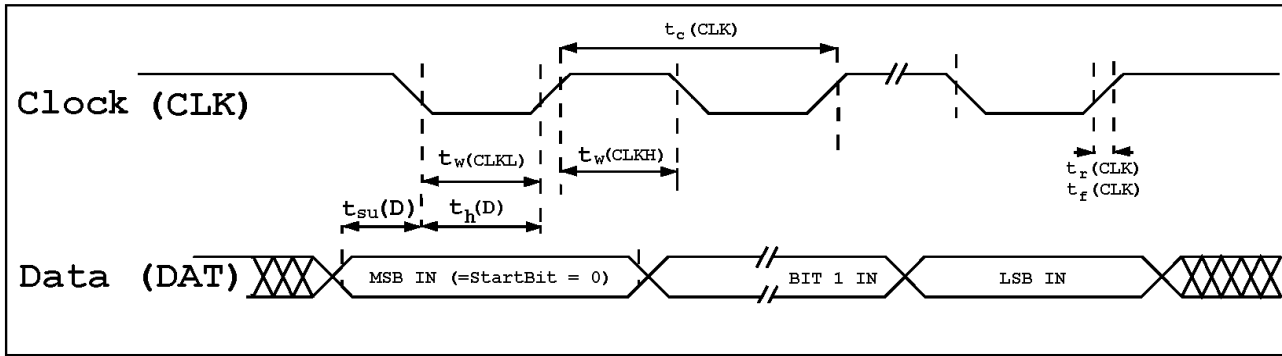

Note: Clock and Data lines must be set to HIGH when inactive.

Symbol	Parameter	Min	Max	Unit
$t_c(\text{CLK})$	SPI Clock frequency	0.06	2	MHz
$t_w(\text{CLKH})$	Clock high time	90		ns
$t_w(\text{CLKL})$	Clock low time	90		ns
$t_{su}(\text{D})$	Data input setup time	140		ns
$t_h(\text{D})$	Data input hold time	100		ns
$t_r(\text{CLK})$	Clock rise time	15		ns
$t_f(\text{CLK})$	Clock fall time		15	ns

Command Set

Synchronous Protocol

The command structure is quite simple as you can see in the following table. Due to the possibility of a permanently applied clock each transmitted data must have a leading “0”. To distinguish between command and data the sixth bit is reserved. There are three sets of commands:

- **Write Data to the LCD Display**
- **Set Backlight Color**
- **Extended Command Set (does not have leading “0” and does not allow for permanently applied clock)**

The first two command sets imply the required data and do not expect a return value from the key. Some commands in the Extended Command set, however, request information to be returned by the key. In this case, the Advanced Technology™ electronics will generate their own clock signal for the data transmission. For details on this scenario, see the **Applications Notes** on our website www.e3-keys.com.

Note: If you are running the keys in a *Legacy Mode*™ environment you cannot use the extended commands since legacy systems do not support returning information from the keys. This may cause a hardware collision, which may result in damage to your system.

Command and Data Formats

Command (binary representation)	Command Name / Description	Comments
01xxxxxx	Command format	“xxxxxx” contains command values according to the Commands table on page 15.
00xxxxxx	Data format	Data to be sent to the key must always have bit 6 reset. Note: All commands and data will have bit 7 reset in order to make the protocol compatible with systems having a permanently applied clock.
xxxxxxxx	Data format	8 Bit data words allowed if there is no permanent clock.

Commands for mixed use with/without permanent clock

Command (binary representation)	Command Name / Description	Comments
01000000 (0x40)	Set Display Address & Write Display Data	<p>All writes to the display must be initiated by this command. Address pointer is auto-incremented by data transmission.</p> <p>The command expects min. 4 data words to follow: 0000000A₈ 0000A₇A₆A₅A₄ 0000A₃A₂A₁A₀ 0000D₃D₂D₁D₀</p> <p>Multiple Data Bytes may follow without additional addressing in one sequence since the controller will perform auto-increment</p> <p>For details see Bit/Pixel Mapping table on page 21.</p>
01000001 (0x41)	Set color	<p>There is one data word to follow: 00R₇R₆G₅G₄B₃B₂</p>
01000010 (0x42)	Set RGB color	<p>There are 3 data bytes to follow: 0D₆D₅D₄D₃D₂D₁D₀ 0D₆D₅D₄D₃D₂D₁D₀ 0D₆D₅D₄D₃D₂D₁D₀</p> <p>Note: The lower 10 values on each color brightness value should only be used for single color applications due to restrictions in the color calibration.</p> <p>These colors may change and should be used with caution until otherwise noted by [E³]</p>
01000011 (0x43)	End Transmission	<p>Ends data transmission to keys and awaits next command sequence. Transmitted commands are begin processed and displayed.</p> <p>This command should be sent after each sequence.</p> <p>Note: The key will not respond to any command issued within 50µs after this command.</p>
01000100 (0x44)	Read Keyswitch ID THIS COMMAND FORCES THE KEYSWITCH TO ANSWER ON THE CLOCK AND DATA LINE.	<p>The answer is consisting of ASCII characters representing the Keyswitch ID and is terminated with CR (0x0D):</p> <p>SB6432</p>
01000101 (0x45)	Read Serial Number THIS COMMAND FORCES THE KEYSWITCH TO ANSWER ON THE CLOCK AND DATA LINE.	<p>The answer is consisting of 4 Bytes which give the serial Number in the following format and is terminated with CR (0x0D):</p> <p>SNYYWW##### Year (04-99) - Week (01-52) - Number (00000 .. 99999)</p>

Additional Commands only available in keys with Enhanced Command Set

Command binary representation (hex representation)	Command Name / Description	Comments
01000111, 00000000 (0x47), (0x00)	Extended command, NOOP	No Operation
01000111, 00000001, D ₇ D ₆ D ₅ D ₄ D ₃ D ₂ D ₁ D ₀ (0x47), (0x01), (0xXX)	Extended command, SetMode * ²⁾	The Display and/or backlight is enabled/disabled while the bitmap data is maintained D ₇ : =1 set Group / =0 only if group matches D ₆ : =1 Display ON* / =0 Display OFF D ₅ : =1 Backlite ON* / =0 Backlite OFF D ₄ : Reserve D _{3..0} Group Number Note: D₇=1 does not only specify group, but executes command as well Note2: Please allow for 2µsec pause as this command has to be performed immediately
01000111, 00000010, D ₇ D ₆ D ₅ D ₄ D ₃ D ₂ D ₁ D ₀ (0x47), (0x02), (0xXX)	Extended command, SetDisplayParam *	This command overwrites the standard setting for the display. Under certain circumstances it may be required to adjust some settings of the display. D ₄ : BIAS D _{3,2} : LCD Refresh rate D _{1,0} : LCD Drive current Note: Setting will be reset after power on and or if there is a incorrect data transmission detected
01000111, 01111111, 11111111, 256 x Pixel Bytes (0x47), (0x7F), (0xFF), 256 x D ₇ D ₆ D ₅ D ₄ D ₃ D ₂ D ₁ D ₀	Extended command, Write Display Data	The display is completely rewritten. 256 bytes of pixel data must follow. First byte is written to Pixel Position 0, as shown in "Bit/Pixel Mapping Table for SA6432 in 8bit enhanced mode" D ₇ D ₆ D ₅ D ₄ D ₃ D ₂ D ₁ D ₀ Note: The amount of Data Bytes must exactly match 256. Note: status of display on/off is unaffected.

* Detailed instruction for use will be available on request. Under normal working conditions there is no need for adjustment.

*²⁾ **Group settings will be lost after power off**

Please note: Enhanced commands are only possible if there is no permanently applied clock.

Command Examples

Set display address to point to upper right corner of display:

01000000 00000000 00000000 00000000 (0x40 0x00 0x00 0x00)

Write Data to Display

Binary	HEX	Comments
010000 00	0x40	Set display address & Write to Display
000000 00	0x00	Data: 00000 for A₈
000000 00	0x00	Data: 00000 for A₇A₆A₅A₄
000000 00	0x00	Data: 00000 for A₃A₂A₁A₀
000001 01	0x05	Write pattern 0101 to LCD Display and increment address by 1
000001 01	0x05	Write pattern 0101 to LCD Display and increment address by 1
000001 01	0x05	Write pattern 0101 to LCD Display and increment address by 1
000001 01	0x05	Write pattern 0101 to LCD Display and increment address by 1

Set backlighting color to light orange:

01000001 00111000 (0x41 0x38)

Binary	HEX	Comments
010000 01	0x41	Set color
00111000	0x38	Red : high intensity, Green medium intensity, Blue off
The 2 individual bits for each color intensity have the following structure: 00 = off 01 = low 10 = medium 11 = high		

End transmission and process data:

01000011 (0x43)

Binary	HEX	Comments
010000 11	0x43	End transmission

Read Keyswitch ID: 01001000 (0x48)		
Binary	HEX	Comments
01001000	0x48	Read Keyswitch ID
<p>The Key will answer by generating its own clock and data signals (see Application Notes at www.e3-keys.com for details)</p> <p>The following examples show the answers for the different SAxxxx types: 0x53 0x42 0x36 0x34 0x33 0x32 0x0D = SB6432 CR</p>		

Read Serial Number: 01001001 (0x49)		
Binary	HEX	Comments
01001001	0x49	Read Serial Number (SNYYWW#####)
<p>The Key will answer by generating its own clock and data signals (see Application Notes at www.e3-keys.com for details)</p> <p>The following example shows the format of the answer: 0x53 0x4E 0x30 0x34 0x30 0x33 0x30 0x35 0x30 0x39 0x33 0x0D = SN040305093CR</p>		

Bit / Pixel Mapping

Display Memory – Internal RAM Structure

The static display RAM holds the data for the LCD display. This data is displayed automatically and is continuously refreshed without further interference from the host controller.

The display RAM is organized into 512 x 4 bits and stores the display data in the SB switch. The content of the display RAM is mapped directly to the LCD display. This RAM can be accessed by the Write LCD Data command, which must be preceded by the Set LCD Address command. The SET LCD Address command tells the key where to write the data and where to display it on the LCD. For actual RAM-Display mapping please refer to the corresponding Bit/Pixel mapping tables below.

Bit/Pixel Mapping Table for SB6432

	Column 63	Column 62	Column 61	Column 60	...	Column 3	Column 2	Column 1	Column 0
Address	1FCH	1F4H	1ECH	1E4H	...	1CH	14H	0CH	04H
Row 16	D ₀	D ₀	D ₀	D ₀	...	D ₀	D ₀	D ₀	D ₀
Row 17	D ₁	D ₁	D ₁	D ₁	...	D ₁	D ₁	D ₁	D ₁
Row 18	D ₂	D ₂	D ₂	D ₂	...	D ₂	D ₂	D ₂	D ₂
Row 19	D ₃	D ₃	D ₃	D ₃	...	D ₃	D ₃	D ₃	D ₃
Address	1FDH	1F5H	1EDH	1E5H	...	1DH	15H	0DH	05H
Row 20	D ₀	D ₀	D ₀	D ₀	...	D ₀	D ₀	D ₀	D ₀
Row 21	D ₁	D ₁	D ₁	D ₁	...	D ₁	D ₁	D ₁	D ₁
Row 22	D ₂	D ₂	D ₂	D ₂	...	D ₂	D ₂	D ₂	D ₂
Row 23	D ₃	D ₃	D ₃	D ₃	...	D ₃	D ₃	D ₃	D ₃
Address	1FEH	1F6H	1EEH	1E6H	...	1EH	16H	0EH	06H
Row 24	D ₀	D ₀	D ₀	D ₀	...	D ₀	D ₀	D ₀	D ₀
Row 25	D ₁	D ₁	D ₁	D ₁	...	D ₁	D ₁	D ₁	D ₁
Row 26	D ₂	D ₂	D ₂	D ₂	...	D ₂	D ₂	D ₂	D ₂
Row 27	D ₃	D ₃	D ₃	D ₃	...	D ₃	D ₃	D ₃	D ₃
Address	1FFH	1F7H	1EFH	1E7H	...	1FH	17H	0FH	07H
Row 28	D ₀	D ₀	D ₀	D ₀	...	D ₀	D ₀	D ₀	D ₀
Row 29	D ₁	D ₁	D ₁	D ₁	...	D ₁	D ₁	D ₁	D ₁
Row 30	D ₂	D ₂	D ₂	D ₂	...	D ₂	D ₂	D ₂	D ₂
Row 31	D ₃	D ₃	D ₃	D ₃	...	D ₃	D ₃	D ₃	D ₃
Address	1F8H	1F0H	1E8H	1E0H	...	18H	10H	08H	00H
Row 0	D ₀	D ₀	D ₀	D ₀	...	D ₀	D ₀	D ₀	D ₀
Row 1	D ₁	D ₁	D ₁	D ₁	...	D ₁	D ₁	D ₁	D ₁
Row 2	D ₂	D ₂	D ₂	D ₂	...	D ₂	D ₂	D ₂	D ₂
Row 3	D ₃	D ₃	D ₃	D ₃	...	D ₃	D ₃	D ₃	D ₃
Address	1F9H	1F1H	1E9H	1E1H	...	19H	11H	09H	01H
Row 4	D ₀	D ₀	D ₀	D ₀	...	D ₀	D ₀	D ₀	D ₀
Row 5	D ₁	D ₁	D ₁	D ₁	...	D ₁	D ₁	D ₁	D ₁
Row 6	D ₂	D ₂	D ₂	D ₂	...	D ₂	D ₂	D ₂	D ₂
Row 7	D ₃	D ₃	D ₃	D ₃	...	D ₃	D ₃	D ₃	D ₃
Address	1FAH	1F2H	1EAH	1E2H	...	1AH	12H	0AH	02H
Row 8	D ₀	D ₀	D ₀	D ₀	...	D ₀	D ₀	D ₀	D ₀
Row 9	D ₁	D ₁	D ₁	D ₁	...	D ₁	D ₁	D ₁	D ₁
Row 10	D ₂	D ₂	D ₂	D ₂	...	D ₂	D ₂	D ₂	D ₂
Row 11	D ₃	D ₃	D ₃	D ₃	...	D ₃	D ₃	D ₃	D ₃
Address	1FBH	1F3H	1EBH	1E3H	...	1BH	13H	0BH	03H
Row 12	D ₀	D ₀	D ₀	D ₀	...	D ₀	D ₀	D ₀	D ₀
Row 13	D ₁	D ₁	D ₁	D ₁	...	D ₁	D ₁	D ₁	D ₁
Row 14	D ₂	D ₂	D ₂	D ₂	...	D ₂	D ₂	D ₂	D ₂
Row 15	D ₃	D ₃	D ₃	D ₃	...	D ₃	D ₃	D ₃	D ₃

CONTROLLING SB SWITCH ARRAYS

Below are sample schematics for controlling one or sixteen SB keyswitches in an array using a PIC16F62X controller to illustrate the simplicity of the control circuitry. Further descriptions including sources are available under the **Application Notes** at our website at www.e3-keys.com.

For additional technical support with your own design implementation, please contact your local [E³] distributor or [E³] at techsupport@e3-keys.com.

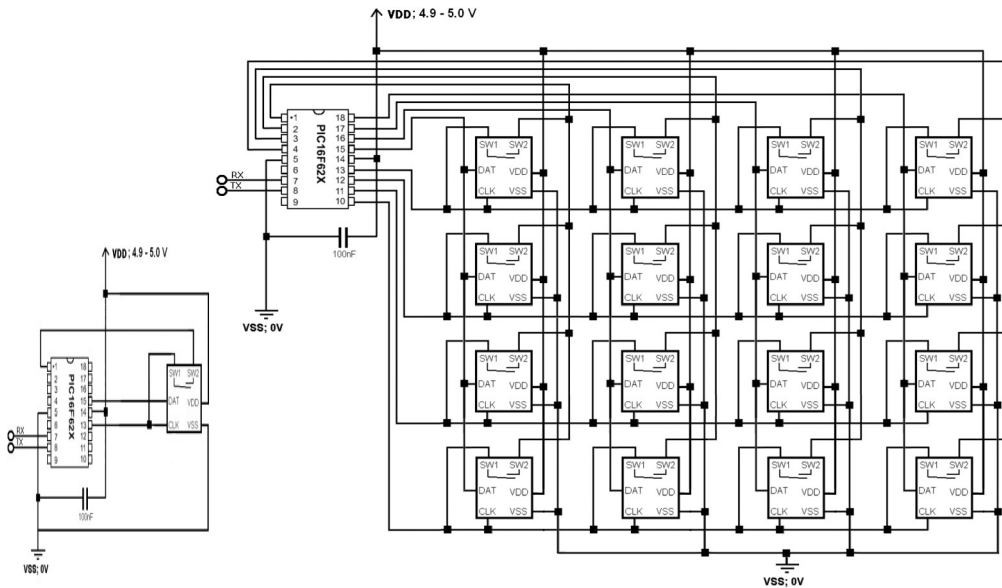

In the above examples the clock and data signals are generated on the corresponding I/O pins of the PIC controller.

NOTICES

Copyright Notice

© 2006-2022 Copyright [E³] Engstler Elektronik Entwicklung GmbH. All rights reserved.

[E³], *The Third Evolution*[™] and *Legacy Mode*[™] are trademarks of [E³]. *The Keys to Intelligence*[™] is a trademark of I/O Universal Technologies, Inc. used with permission. All other trademarks are property of their respective owners.

No part of this publication may be copied, photocopied, reproduced, translated or reduced to any electronic medium or machine-readable form without the expressed written consent of [E³] Engstler Elektronik Entwicklung GmbH.

Technical Notice

This datasheet is intended for technically qualified personnel trained in the field of electronics.

The knowledge of electronics and the technically correct implementation of the content of this datasheet are required for problem free installation, implementation and safe operation of the described product. Only qualified personnel have the required know-how to implement the specifications given in this data sheet.

For clarity, not all details regarding the product or its implementation, installation, operation, or maintenance have been included. Should you require additional information or further assistance, please contact your local [E³] distributor or [E³] Engstler Elektronik Entwicklung GmbH at techsupport@e3-keys.com. You may also visit our website at www.e3-keys.com.

Flammability Ratings

The SB6432 base is rated UL94-V0; all other plastics are rated UL94-HB.

Warranty Disclaimer

[E³] ENGSTLER ELEKTRONIK ENTWICKLUNG GMBH grants no warranty with respect to this data sheet, neither explicit nor implied, and it is not liable for direct or indirect damages. Some states do not grant the exclusion of incidental or consequential damages and, therefore, this statement may not be valid in such cases.

This data sheet has been produced with all due care. However, since errors cannot be excluded, [E³] Engstler Elektronik Entwicklung GmbH does not grant any warranty or accept any legal responsibility or liability in any form for erroneous statements herein.

ORDERING INFORMATION

Part Number	Description
SB6432-B	SB pushbutton keyswitch with 64 x 32 pixel display Backlit in 64 RGB colors Black housing (RAL 9005)

CHANGE HISTORY

Version	Date	Comments
0.1	02/22/06	Initial draft document
0.2	03/02/06	Revised and released as PRELIMINARY
1.0	03/28/06	Release version
1.1	07/10/07	I/O data pin capacitance value changed
1.2	03/18/08	SB, Sxnnnn nomenklatur corrected
1.3	07/14/20	Updated to new formatting
1.4	06/06/22	Minor updates for consistency
2.0	06/22/22	Updated release version

[E³] Engstler Elektronik Entwicklung GmbH
Industriering 7 • 63868 Grosswallstadt • Germany
WWW.E3-KEYS.COM